

MANUAL
TYRE CHANGER
MO300/320

MO300/320

Information

Neither personal nor its affiliates shall be liable to the purchaser of this unit or third parties for damages, losses, costs, or expenses incurred by purchaser or third parties as a result of: accident, misuse, or abuse of this unit, or unauthorized modifications, repairs, or alterations to this unit, or failure to strictly comply with our company operating and maintenance instructions.

Our company shall not be liable for any damages or problems arising from the use of any options or any consumable products other than those designated as original our company products or approved products by our company.

This manual instruction is suitable for tyre changer of the 9 serials.

This unit is made for the purpose of persons who have special techniques and certifications.

Safety Precautions

- This manual is a necessary part of the product. Please read carefully.
- Keep the manual for later use when maintaining the machine.
- This machine can only be used for the designated purposes. Never use it for any other purpose. The manufacturer is not held responsible for the damage incurred by improper use or use other than the intended purpose.
- The equipment can only be operated by qualified personnel with special training. Modification to any components or parts, or use the machine for other purpose without either obtaining the agreement from the producer, or observing the requirement of the instructions may lead to direct or indirect damage to the equipment.
- This machine should be installed on the stable ground.
- Keep the back panel 0.5m away from the wall for good ventilation. Enough room should be left on both sides of the machine for convenient operation.
- Do not put this machine in a place with high temperature or moisture, or near the heating system, water tap, air-humidifier or furnace.
- Do not put the machine near the window with sunlight. Protect the unit with a curtain or shield if necessary.
- Avoid lots of dust, ammonia, alcohol, thinner or spraying binder.
- People who are not operating the machines should be kept away when it is used.
- Use appropriate equipment and tools, protective and safety equipment, including eyeglasses, earplugs and working boots.
- Pay special attention to the safety marks on the machine.
- Do not touch or approach the moving parts by hand during operating.
- Do not remove the safety device or override it.
- Use #2 lithium lubricants (grease) only within the safety range. Refer to the appendix for the safety data.
- Before moving the tyre changer, contact maintenance personnel.
- The product can only be used under the following conditions:
 - Temperature: 0°C ~45°C
 - Relative humidity: 30-95%

Table of Contents

I. WARNING SIGN	3
II. INTRODUCTION	4
III. SAFETY REQUIREMENT	6
IV. TRANSPORT	6
V. UNPACKING.....	7
VI. INSTALLATION.	7
VII. OPERATION	8
VIII. INFLATION.....	11
IX. MOVING	13
X. STORAGE.....	13
XI. SCRAPPING	13
XII. MAINTENANCE	13
XIII. ASSISTANT ARM (AL320) OPERATION.....	6
XIV. ELECTRIC CONNECTION DIAGRAM	24
XV. EQUIPMENT EXPLOSION	26

I. Warning Sign



- To prevent accidents from occurring, make sure to keep hands and other body parts away when fastening the mount/demount head or when the turntable is running.



- High voltage power! Dangerous!



- Be careful when connecting and disconnecting air source. Bleed the air in the cylinder completely when maintaining the air pipes to prevent accidents from occurring

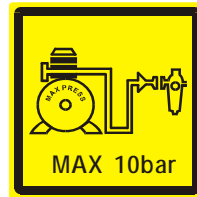

- The pressure of the compressed air should not exceed 10 bar.



- Caution should be taken when separating the tyre from rim. The bead breaker shoe will move rapidly and forcefully when the pedal is depressed. Keep body and materials away from the work area.



- This is where the compressed air gun is connected with the air pipe. Connect the compressed air gun with the air connector.



- Don't keep hands or other body parts between the clamping jaw and clamping rim.



- Before inflating check if the clamping rim and the tyre match each other, and if they are in good condition. Any negligence may result in a fatal explosion. Similar accident may occur if the inflating air exceeds the allowed pressure.



- If the clamping cylinder is open during clamping, squeezing on hands can be resulted. Remember to keep hands away from the inside of the tyre when clamping.

II. Introduction

Thank you for purchasing our tire changers. The machine has been manufactured in accordance with the very best quality principles. This manual is one integral part of the product. Before using the tire changer, read carefully the warnings and instructions contained in this manual since they provide important information on operation safety and maintenance.

Keep this manual for future reference.

1. Technical Data

Model	LT-900A	LT-980A	LT-910/LT-950
Max tire diameter	1100mm (43")	1100mm (43")	1100mm (43")
Max tire width	13" (330mm)	15" (381mm)	15" (381mm)
Internal locking rim dimensions	14"-24" (356-610mm)	15"-26" (381-660mm)	15"-26" (381-660mm)
External locking rim dimensions	12"-22" (305-559mm)	13"-24" (330-610mm)	13"-24" (330-610mm)
Force on bead breaker blade	2500Kg (5500Lb)	2500Kg (5500Lb)	2500Kg (5500Lb)
Working pressure	0.8-1.2Mpa (8-12bar)	0.8-1.2Mpa (8-12bar)	0.8-1.2Mpa (8-12bar)
Power supply voltage	220V/110V/380V	220V/110V/380V	220V/110V/380V
Motor power	1.1kw/0.75Kw	1.1kw/0.75Kw	1.1kw/0.75Kw
Noise level in working conditions	<70dB	<70dB	<70dB

2. Description of Machine

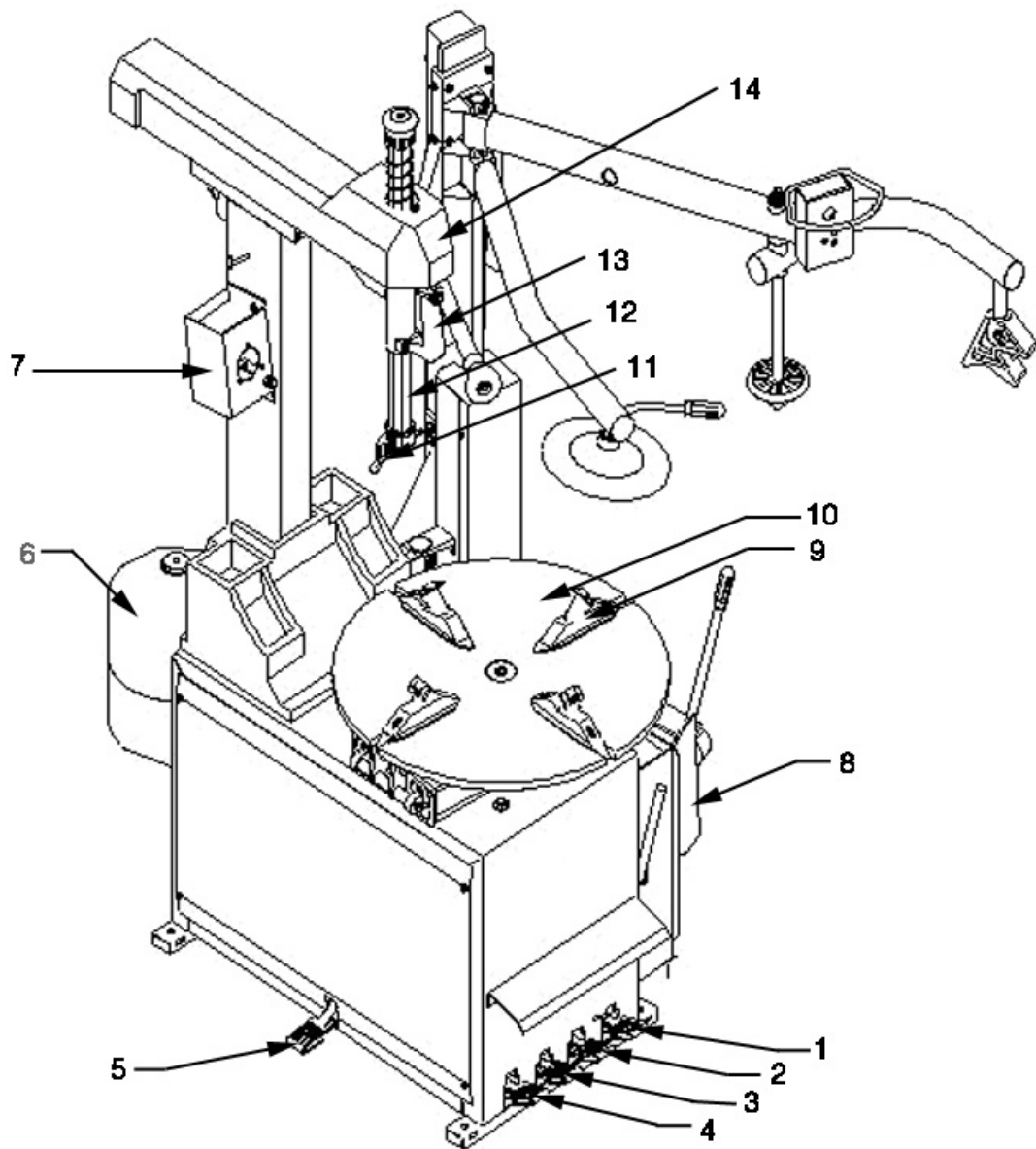

1. Reverser control pedal
3. Clamp control pedal
5. Inflating pedal
7. Inflator box
9. Jaw
11. M/D head
13. Handle

2. Bead breaker control pedal
4. Tilting arm pedal
6. Air Tank (optional)
8. Wheel Support
10. Turntable
12. Hex bar
14. Cover

III. Safety Requirement

1. Usage

This tire changer has been designed and manufactured exclusively for removing and mounting tires from/into rims from 10" to 22" and a maximum diameter of 1100mm.

Any other use is to be considered incorrect and unreasonable.

In particular THE MANUFACTURE can't be held responsible for any damage caused through the use of this tire changer for purposes other than those specified in this manual, and therefore inappropriate, incorrect and unreasonable.

2. General Safety Precautions

This tire changer may only be used by specially trained and authorized expert personnel.

Any tampering and modification to the equipment carried out without the manufacturer's prior authorization will free him from all responsibility for damage caused directly or indirectly by the above actions.

The tire changer comes complete with instructions and warning transfers which are designed to be long-lasting. If they should for any reason be damaged or destroyed, please ask immediately for replacements from the manufacture.

Keep it away from combustible, explosive objectives, avoid strong light, sunshine, and keep it in good ventilation.

Make sure to use original spare parts and accessories, installed by authorized personnel according to manual.

Be careful if there are any dangers happen, stop the machine, contact manufacturer.

Non-operation personnel should be kept away from the machine.

Operators should be protected by protective (glove, eye-protection glasses, and working-clothes) to avoid any accidental injuries.

IV. Transport

This tire changer must be transported in its original packaging and kept in the position shown on the package itself.

The packaged machine may be moved by means of a fork lift truck of suitable capacity. Insert the forks at the points shown at figure below.

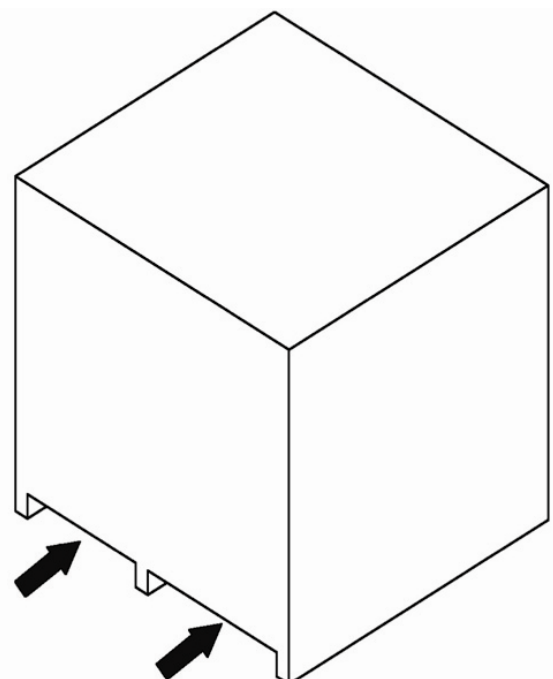

V. Unpacking

Use proper protection tools to unpack (gloves etc)

Check that the equipment is in perfect condition, making sure that no parts are damaged or missing, if in doubt do not use the machine and contact your retailer.

Put the packing materials (plates, nails, screws, plastic bags) in safety place.

VI. Installation.

1. Space Required

When choosing the place of installation is sure that it complies with current safety at work regulations.

This machine must be connected to the mains electric power supply and the compressed air system. It is therefore advisable to install the machine near these power sources.

The place of installation must also provide at least the space shown in figure below so as to allow all parts of the machine to operate correctly and without any restriction.

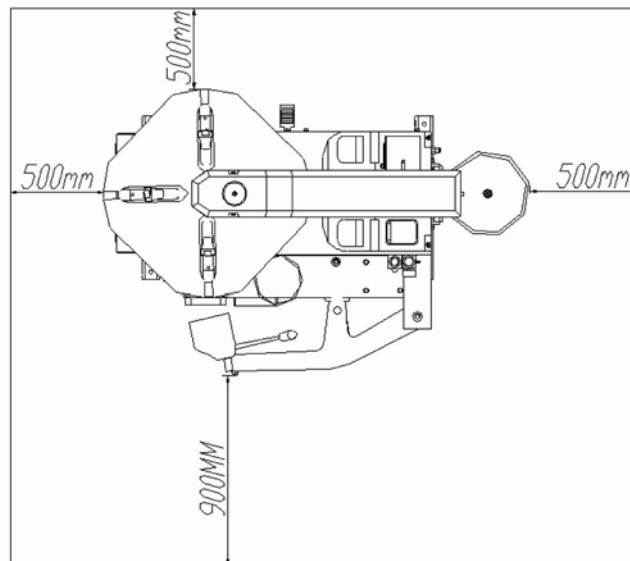

If this machine is installed outside it must be protected by a lean-to.

2. Commission

Before making the connections, check that the characteristics of your systems correspond to those required by the

machine.

Even small jobs done on the electrical system must be carried out by professional personnel.

Connect the machine to the electrical network, which must be provided with line fuses, a good earth plate in compliance with regulations in force and it must be connected to automatic circuit breaker.

Warning: Should the tire changer be lacking in electric plug, so the user must set one, which is at least 16A and which conforms to the voltage of the machine, in compliance with the regulations in force.

3. Operation Test

When the pedal (1) is pressed down the turntable should turn in clockwise direction. When the pedal is pulled up the turntable should turn in the anticlockwise direction. Warning: if the turntable turns in the opposite direction to that shown, reverse the wires in the three-phase plug.

Pressing the pedal (2) activates the bead breaker; when the pedal is released the bead breaker returns to its original position.

Pressing the pedal (3) opens the four clamps; when the pedal is pressed again they close.

Pressing the pedal (4) tilts the arm; when the pedal is pressed again it returns to its working position.

When the pedal located on the left side of the machine is pressed down to the first gear, air is released from the airline gauge. Gauge will indicate the pressure after release of air.

When the pedal located on the left side of the machine is pressed down to the second gear, air is released from the airline gauge along with a powerful jet from the nozzles located on the turntable clamps.

Don't lean on the turntable during this operation, possible dirty dust on the turntable could offend the operator's eyes.

For the same reason, be carefully as not to accidentally push the inflating pedal while working.

VII. Operation

Don't use the machine until you have read and understood the entire manual and the warnings it provides.

The operation of the tire changer is divided into three parts:

1. Breaking the bead
2. Demounting the tire
3. Mounting the tire;

Warning: before carrying out any operation, deflate the tire and take off all the wheel balancing weights.

1. Breaking the bead

Warning: when the bead breaker pedal is operated, anything within the action range of bead breaker arm can be in the danger of being crushed.

Check that tire is deflated, if not, deflate it.

Close the turntable clamps completely.

Warning: bead breaker with the clamps in the open position can be extremely dangerous for operator's hands; during the bead breaking operations never touch the side of the tire.

Position the wheel against the rubber stop on the right side of the tire changer. Position the bead breaking blade against the tire bead at a distance of about 1 cm from the rim. Pay attention to the blade, which must be correctly onto the tire not onto the rim.

Press down the pedal (2) to activate the bead breaker and release it when the blade has reached to the end of its travel or in any case when the bead is broken.

Rotate the tire slightly and repeat the operation around the entire circumference of the rim and from both sides until the bead is completely detached from the rim.

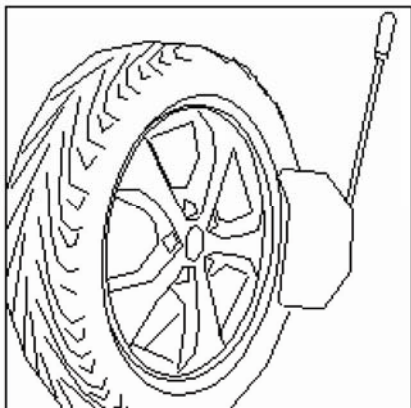

**Figure
7-1**

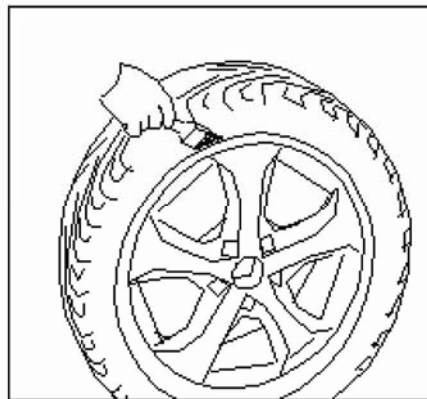

**Figure
7-2**

2. Demounting the Tire

Before any operations remove the old wheel balancing weights and check that the tire is deflated.

When tilting the vertical arm, be sure that nobody stands behind the tire changer. Press down pedal (4), tilt the vertical arm, and clean the turntable.

Spread the grease onto the tire bead.

Failure to use the grease risks causing serious damage to the tire bead.

When clamping the tire, never have your hands under the tire. To clamp the tire correctly, position the wheel exactly at the center of the turntable.

1) Rim locking from outside:

Position the clamps according to the reference mark on the turntable by pressing the pedal down to its intermediate position.

Place the tire on the clamps and, keeping the rim pressed down, press the pedal (3) as far as it will go.

2) Rim locking from inside:

Position the clamps so that they are completely closed.

Place the tire on the clamps and press down the pedal (3) to open the clamps and thereby lock the rim.

Make sure the rim is firmly fixed to the clamps.

Press the pedal (4), restore the vertical arm to its working position.

Push out the locking button in the handle, release hex bar.

Lower the hex bar until the mounting tools rests against the edge of the rim.

Then lock it using the locking button in the handle. This way the mounting arm is locked in a vertical and horizontal direction and the mounting head is automatically moved to a distance of about 2mm from the rim.

Do not put hands on the wheel, when moving the mounting arm to its working position your hand could be crushed between the rim and the mounting head with the crowbar inserted between the bead and the front section of the mounting head, move the tire bead over the mounting head.

WARNING: In order not to damage the inner tube, if there is one, it is advisable to carry out this operation with the valve 10cm to the right of the mounting head.

Chains, bracelets, loose clothing or foreign objectives in the vicinity of moving parts can cause danger to the operator.

With the crowbar held in this position, rotate the turntable in a clockwise direction by pressing down on pedal (1) until the tire is completely separated from the wheel rim. To prevent industrial accidents, keep hands and other parts of the body as far as possible from the tool arm when the table top is turning.

Remove the inner tube if there is one, need not release the mounting arm, press down pedal(4), directly tilt the vertical arm.

Repeat the operation for the other tire bead

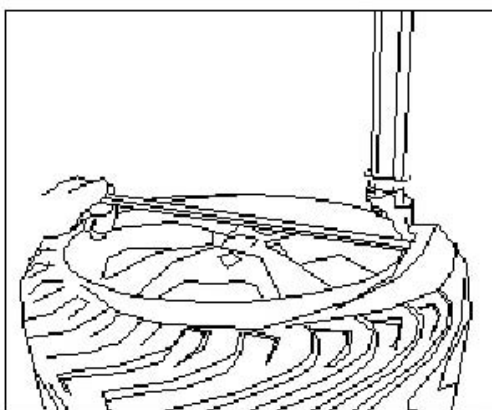

Figure 7-3

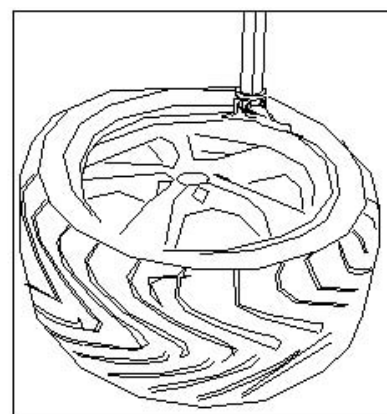

Figure 7-4

3. Mounting the Tire

Warning: this checking of tire and rim is of utmost importance to prevent tire explosion during the inflating operation.

Before beginning mounting operation make sure that:

The tire and the cord fabric are not damaged. If you note the defects, do not mount the tire.

The rim is without dents and is not warped. Attention with alloy rims, dents because internal micro-cracks not visible to naked eye. This can compromise the rim and also be the source of danger especially during inflation.

The diameter of the rim and tire are exactly the same. Never try to mount a tire on a rim if you cannot identify the diameter of both.

Lubricate the tire beads with the special grease in order to avoid damaging them and to facilitate the mounting operations.

When tilting the vertical arm, make sure that nobody stands behind the tire changer.

When you are working with the rims of the same size, it is not necessary always to lock and unlock the hex bar. Just tilt and restore the vertical arm with the horizontal arm and mounting arm locked.

Move the tire so that the bead passes below the front section of the mounting head and is brought up against the edge of the rear section of the mounting head itself. Keep the tire bead pressed down into the wheel rim channel with your hands, press down on the pedal (1) to rotate the turntable clockwise. Continue until you have covered the whole circumference to the wheel rim; insert the inner tube (if there is one).

Repeat the same operations to mount the upper side of the tire.

WARNING: dismounting and mounting are always done with the clockwise turntable rotation. Anticlockwise rotation is used only to correct operator's errors or if the turntable stalls.

VIII. Inflation

The greatest attention is called for when inflating the tires. Keep strictly to the following instructions since the tire changer is not designed and built to protect the user (or anyone else in the vicinity of the machine) if the tire bursts accidentally.

A burst tire can cause serious injury or even death of the operator.

Check carefully that the wheel rim and the tire are of the same size.

Check the state of wear of the tire and that it has no defects before beginning the installation stage.

Inflate the tire with brief jets of air, checking the pressure after every jet.

Maximum inflating pressure is 0.8MPa. In any case never exceed the pressure recommended by the manufacturer.

Keep your hands and body as far away as possible from the tire.

1. Bead Blasting

There is a pedal on the side of the machine. This pedal has two positions. The first position is for the inflation for the tire with tube. Step the pedal lightly for several times during the inflation. Make sure the reading on the gauge does not exceed the manufacturer's limit .

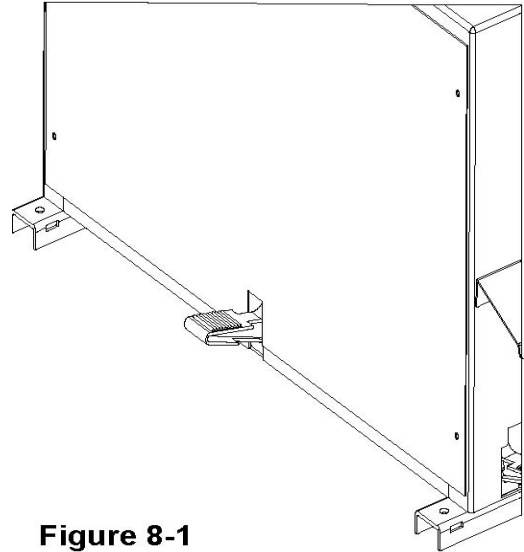

Figure 8-1

The second position is for the inflation for the tubeless tire, step the pedal down fully to the bottom, and then make the pedal to the first position to continue the inflation. Make sure that the reading on gauge doesn't exceed the manufacturer's limit.

Warning: the operator should wear safety goggles when operating.

2. Inflating tire using airline gauge:

Inflate a tire proceed as follows:

Connect the airline gauge fitting to the tire valve.

Make a last check to be certain that the tire and rim diameter correspond.

Between air jets, constantly check the pressure until required pressure has been reached explosion hazard!

Never exceed 0.8MPa, when inflating tire on a fixed position. If a higher inflating pressure is required remove the wheel from the turntable and continue the inflation inside a special protection cage (commerciallyavailable).

Never exceed the max. Inflating pressure given by the tire manufacturer.

Always keep hands and body back from inflating tire.

Only specially trained personnel are allowed to perform these operations .do not allow other persons to operate or to stay near the tire changer.

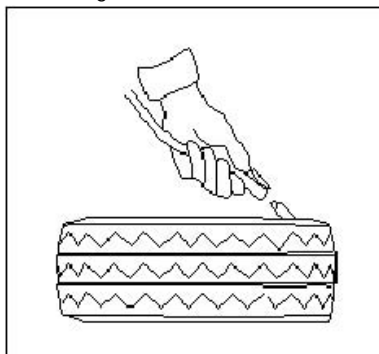

Figure 8-1

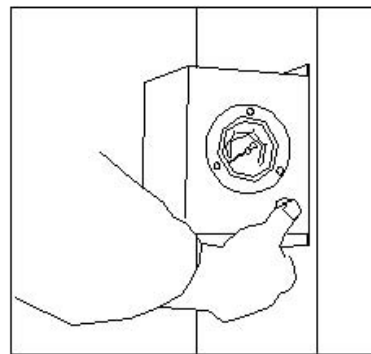

Figure 8-2

IX. Moving

Move the tire changer you need a fork-lift truck.

Disconnect the pneumatic and electric power supplies.

Apply leverage to one side of the base so as to raise it slightly from the floor, Insert the forks of the truck under the base and slide the tire changer onto them.

Set the tire changer down in its new position.

X. Storage

In the event of storage for long periods of time, make sure to disconnect all sources of power and grease the clamp sliding guides on the turntable to prevent from oxidizing.

XI. Scrapping

If you decide scrape the machine, be sure to make it inoperative by disconnecting it from all sources of power.

Remove all non-ferrous materials and dispose of them as prescribed by national law.

Collect the oil and dispose of it at an authorized point as prescribed by national law.

Scrape the rest ferrous material.

XII. Maintenance

1. General warning

Unauthorized personnel may not carry out maintenance work.

Regular maintenance as described in the instructions is essential for correct operation and long lifetime of the tire changer.

If maintenance is not carried out regularly, the operation and reliability of the machine may be compromised, thus placing the operator and anyone else in the vicinity at risk. Before carrying out any maintained work, disconnect the electric and pneumatic supplies. Moreover, it is necessary to break the bead load less 3-4 times in order to let the air in pressure go out of the circuit.

Defective parts must be replaced exclusively by expert personnel using the manufacture's spare parts.

Removing or tampering with safety devices (pressure limiting and regulating valves) represents a contravention of safety regulations. In particular, the manufacturer shall not be held responsible for complaints deriving from the use of spare parts made by other manufacturers or for damage caused by tampering or removal of safety systems.

2. Maintenance Operations

Clean the turntable once a week with diesel fuel so as to prevent the formation of dirt, and grease the clamp sliding guides.

Carry out the following operations at least once every 30 days:

Check the oil level in the lubricator tank. If necessary, fill up by unscrewing screw 2; only use SAE30 oil (figure 12-1)

Check that a drop of oil is injected into the reservoir, every 3-4 times the pedal is pressed down, one drop every 3-4 times pressing. If not, regulate using the screw (2) (figure 12-1).

Retighten the clamp tightening screws (1) and the screws on the turntable slides (2). (Figure 12-2)

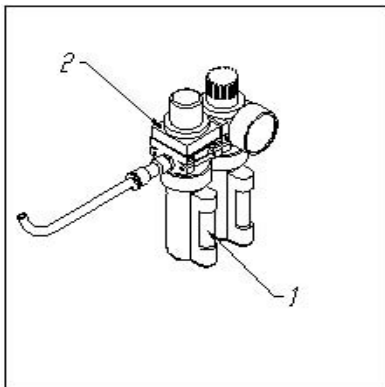

Figure
12-1

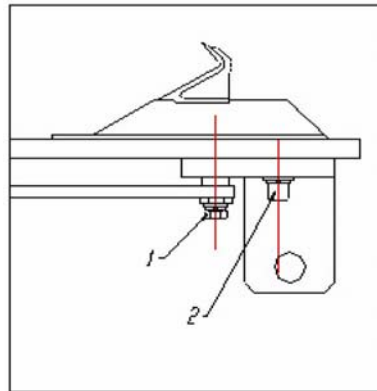

Figure
12-2

If the turntable doesn't work, it may be caused by loose drive belt, check it as follows: Before any operations, please disconnect the electric power supplies.

Remove the left side body panel of the tire changer. Tighten the drive belt by means of the special adjusting screw (1) on the motor support.

It is necessary to adjust the screw (1) in the locking plate of the mounting arm, if the mounting head doesn't lock or it doesn't rise from the rim of 2mm necessary for working. (figure 12-4)

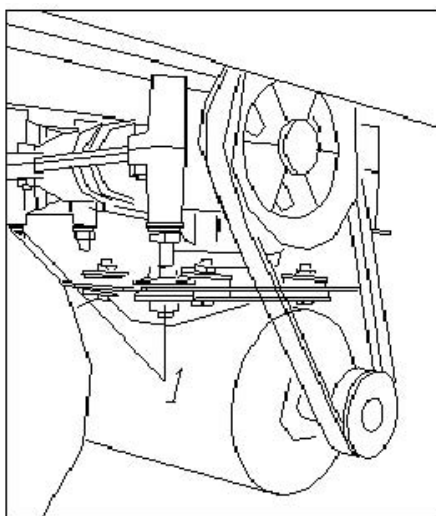

Figure 12-3

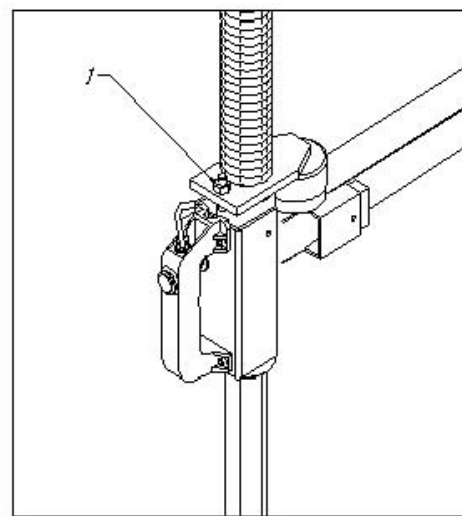

Figure 12-4

If clamps or bead breaker open/close slowly, it is necessary to clean or replace the silencer, and proceed as follows :(Figure 12-5)

- 1) Remove the left side panel of the machine.
- 2) Unscrew the silencer put on the clamp opening/closing pedal.
- 3) Clean by a jet of compressed air or, if damaged, replace by referring to the spare parts catalogue.

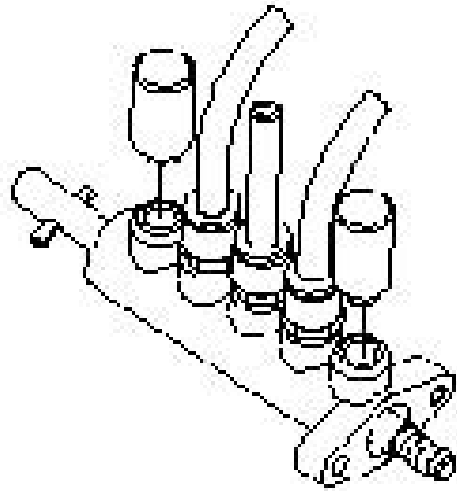
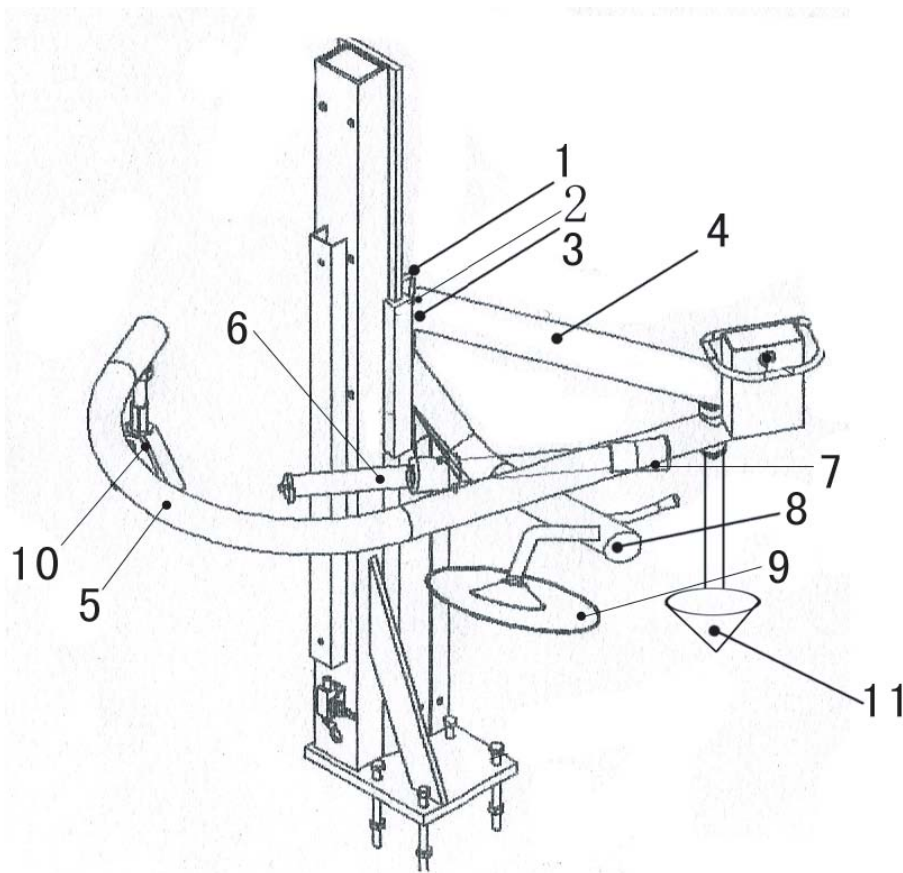

Figure 12-5

XIII. Assistant Arm (AL320) Operation

1. Structure



- | | | |
|----------------|----------------------|-------------------------|
| 1. Guiding Bed | 2. Adjusting Screw | 3. Gliding Block |
| 4. Main Arm | 5. Block Holding Arm | 6. Roller Holding Shaft |
| 7. Roller | 8. Disc Holding Arm | 9. Disc |
| 10. Block | 11. Cone | |

2. Safety requirement

Any other use is to be considered incorrect and unreasonable.

Read this manual carefully before using it; Make sure that you understand how to operate this machine and the notices.

THE MANUFACTURE can't be held responsible for any damage caused through the use of this machine for purposes other than those specified in this manual, and therefore inappropriate, incorrect and unreasonable.

General safety precautions

This machine may only be used by specially trained and authorized expert personnel.

-
- 1) Any tampering and modification to the equipment carried out without the manufacturer's prior authorization will free him from all responsibility for damage caused directly or indirectly by the above actions.
 - 2) Keep it away from combustible 、 explosive objectives; avoid strong light, sunshine, and good ventilation.
 - 3) Make sure to use original spare parts and accessories.
 - 4) Installed by authorized personnel according to manual.
 - 5) be careful if there are any dangers happen stop the machine, contact manufacturer.
 - 6) Non-operation personnel should be kept away from the machine.
 - 7) Operators should be protected by protective materials (glove, eye-protection glasses, and working-clothes) to avoid any accidental injuries.

3. Unpacking

- 1) Use proper protection tools to unpack (gloves etc)
- 2) Check that the equipment is in perfect condition, making sure that no parts are damaged or missing, if in doubt do not use the machine and contact your retailer.
- 3) Read the packing list carefully; check if there is any missing, if in doubt contact your retailer.
- 4) Put the packing materials (plates, nails, screws, plastic bags)in safety place.
- 5) Deal with any contamination or dissolvable materials contained in the packing box according to local laws.

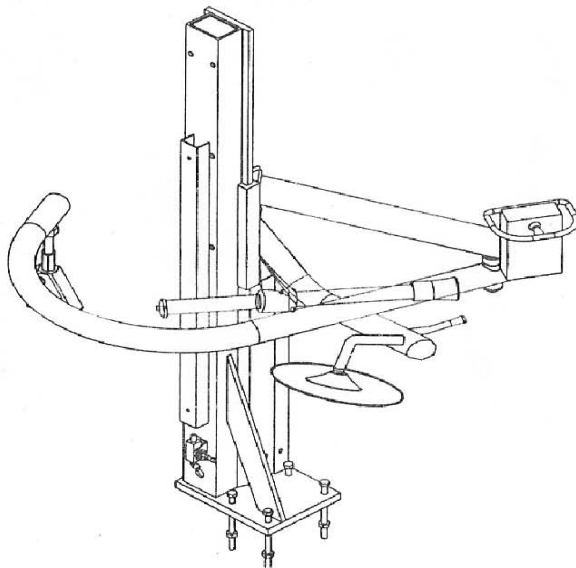
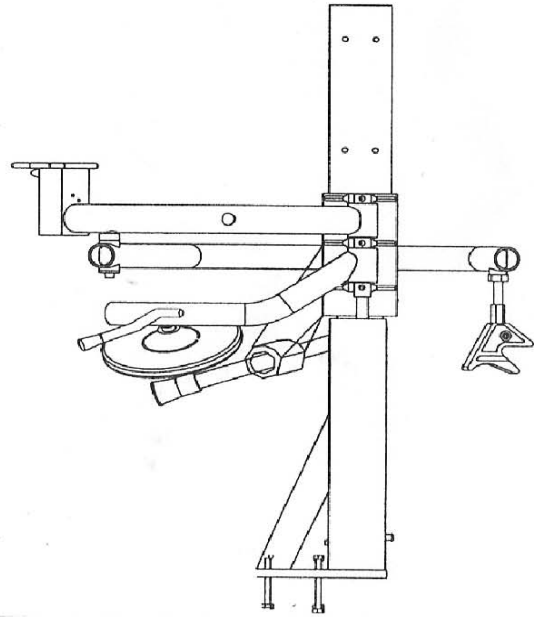
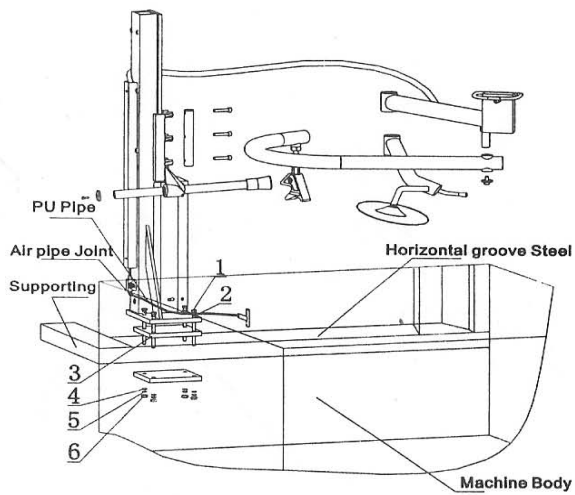

4. Installation instructions for AL320 Device

- 1) Open the packing for the well packed mainpulator complete(AL-320 Device)carefully and place it onone side of the bead breaker blade on the machine body;
- 2) Put one of the vertical arm padding plates(2 pieces/machine,see Picture3) onto the horizontal slot steel ,aim it at the hole on the slot steel;
- 3) Put the vertical arm complete onto the padding plate and aim it at the hole, the thread the four bolts & flat washers(see Picture 1 & 2) through the holes;
- 4) Place the other vertical padding plate onto the bolt(below) the slot steed), install the flat washers,spring washers

& the nuts(see Picture 4,5,6) in turn, then fasten them carefully;

- 5) Connect the Pu pipe with the joint of the device;
- 6) Refer the below drawings & the list on the left for the other installation operations

5. Operation Test

- 1) Connect to air source; make sure the pressure of air source is enough.
- 2) Pull up pneumatic-controlled valve, the upper part of the machine moves up.
- 3) Release pneumatic-controlled valve, the upper part of the machine stops.
- 4) Press pneumatic-controlled valve, the upper part of the machine moves down.
- 5) Move

6. Operation

Functions of the machine.

- 1) Auxiliary fixes of dismounting head and insert crowbar Dismantle the side of tire according to correct rim size, press the upper side of tire with tire press roller ,fix the dismounting head and insert crowbar(figure 6-1),move up the tire press roller and remove it, you can move the upper rim of tire to the dismounting head.

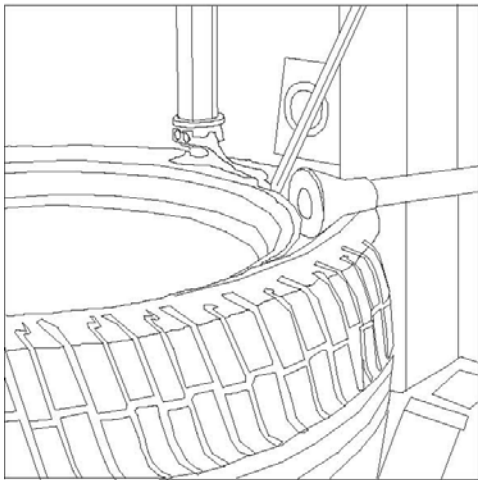

Figure 6-1

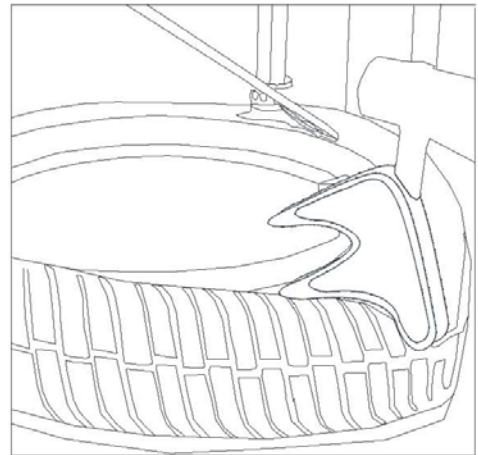

Figure 6-2

- 2) Help crowbar to get the upper side of tire out If the upper side of tire is too hard to get out, you can use tire press lump to press the upper side rim of tire of the opposite side into the groove, and then get the upper side of tire.
- 3) Help hold the lower part of tire up If the lower part of tire is too hard to be moved up, you can use disk to hold the tire up and rotate the tire, then the downside of tire can be hold to the surface of the rim, you can insert a shaft to

dismantle the rim of the tire. (Figure 6-3)

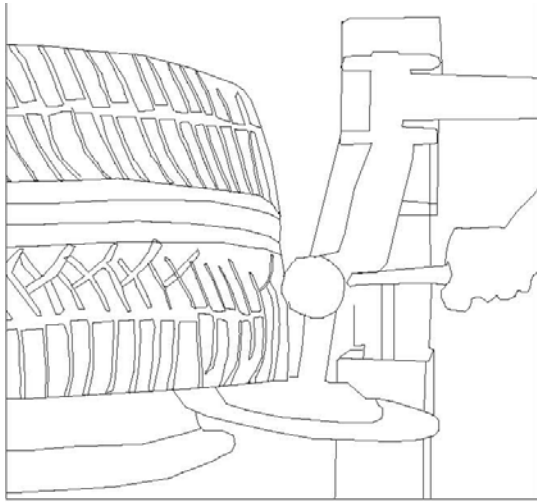

Figure 6-3

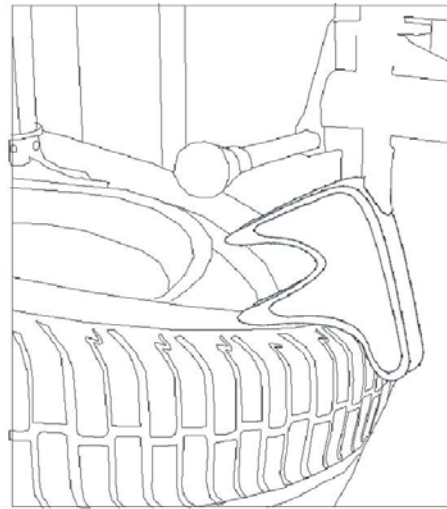

figure 6-4

4) Help mount the upper rim of tire

Mount the upper rim of tire, make upper rim rest on the upper surface of the dismantling head, use tire press roller and tire press block to press the upper side of tire simultaneously (figure 6-4), rotate tire to mount the upper side of tire. This is to ensure the already mounted upper side of tire can slide into the groove of the rim. The position requirement after Tire press roller and tire press block being simultaneously pressed: tire press roller can't contact dismantling head or the steel rim. The upper rim doesn't detach from the upper surface of dismantling head due to bigger pressure, after rotation the upper rim of tire can get into the inner groove of rim. The comparative height is different according to different rim requirement, can loose screws to adjust the height of tire press clump. (Figure 6-5).

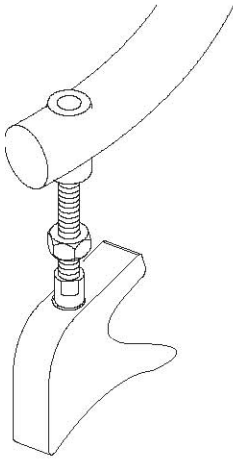

Figure 6-5

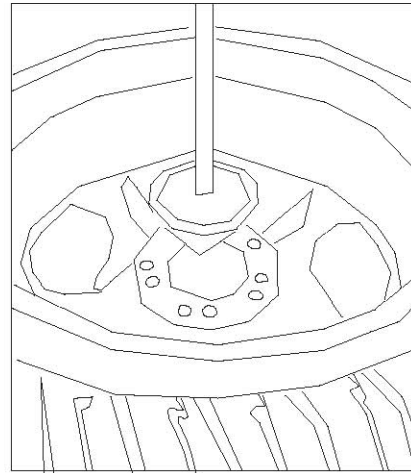

Figure 6-6

5) Help to fix the rim

If the lower rim of tire is too tight, clamps can't catch the rim, you can use cone-shape tools to fix the rim. make the clamps to open to a suitable distance, make it just a little bigger than the outer rim, put the tire, make the outer rim locate inside the clamps, use cone-shape tools (figure 6-6) to downward press rim, make clamps higher than the low surface, close clamps to fix the rim.

Warning:

Tire holding disk can't touch steel rim or working disk.

Tire press roller can't touch dismantling head or steel rim.

Watch if it can touch other parts of the machine during work. Otherwise halt the machine.

Auxiliary facility can't replace.

7. Storage

In the event of storage for long periods of time, be sure to disconnect all sources of power

Keep in good ventilation, dry place, and movable parts should be fixed.

Grease the clamp sliding guides on the turntable to prevent from oxidizing.

8. Scrapping

If you decide scrape the machine, be sure to make it inoperative by disconnecting it from all sources of power.

Remove all non-ferrous materials and dispose of them as prescribed by national law.

Collect the oil and dispose of it at an authorized point as prescribed by national law.

Scrape the rest ferrous material.

9. Maintenance

Tighten the fixing screws timely.

Dust-cleaning need be done to guiding bed and gliding block timely.

Apply lubricant in guiding bed, gliding block and the shaft of air cylinder.

10. General questions and resolve

1). Insufficient pressure during work

Adjust the pressure of air source to required pressure, check if there're any parts of leaking, and replace the defect parts.

2). Working parts don't run smoothly

Adjust screws on gliding block; ensure the distance not too big between guiding bed and slide.

Warranty

THIS WARRANTY IS EXPRESSLY LIMITED TO PERSONS WHO PURCHASE OUR COMPANY PRODUCTS FOR PURPOSES OF RESALE OR USE IN THE ORDINARY COURSE OF THE BUYER'S BUSINESS.

Our company electronic product is warranted against defects in materials and workmanship for one year (12 months) from date of delivery to the user. This warranty does not cover any part that has been abused, altered, used for a purpose other than for which it was intended, or used in a manner inconsistent with instructions regarding use. The exclusive remedy for any automotive meter found to be defective is repair or replacement, and our company shall not be liable for any consequential or incidental damages. Final determination of defects shall be made by our company in accordance with procedures established by our company. No agent, employee, or representative of our company has any authority to bind our company to any affirmation, representation, or warranty concerning our company automotive meters, except as stated herein.

Disclaimer

THE ABOVE WARRANTY IS IN LIEU OF ANY OTHER WARRANTY, EXPRESSED OR IMPLIED, INCLUDING ANY WARRANTY OF MERCHANTABILITY OR FITNESS FOR A PARTICULAR PURPOSE.

Order Information

Replaceable and optional parts can be ordered directly from your LAUNCH authorized tool supplier. Your order should include the following information:

1. Quantity
2. Part number
3. Item description

Customer Service

If you have any questions on the operation of the unit, please contact us:

Tel: 86-417-6669785,

Fax: 86-417-6669786,

If your unit requires repair service, pls contact with the manufacturer with a copy of the sales receipt and a note describing the problem. If the unit is determined to be in warranty, our company will give technical advice and free parts replacement. If the unit is determined to be out of warranty, it will be repaired for a nominal service charge plus return freight. Send the unit pre-paid to:

Attn: A/S Department
6#, Hign-tech
Industry Developing District.,
Yingkou City, Liaoning Province, P.R.China
P.C.: 115004

XIV. Electric Connection Diagram

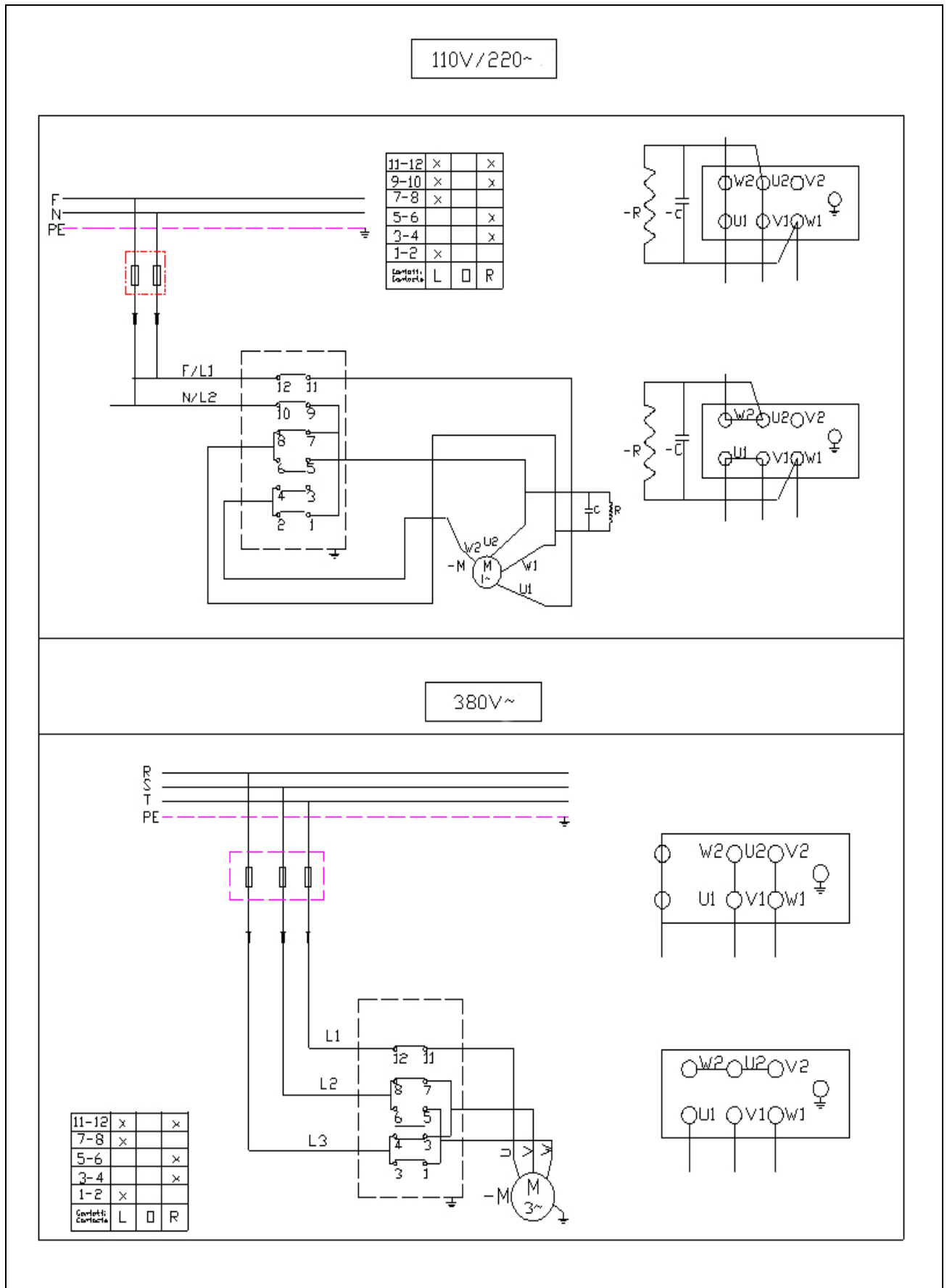

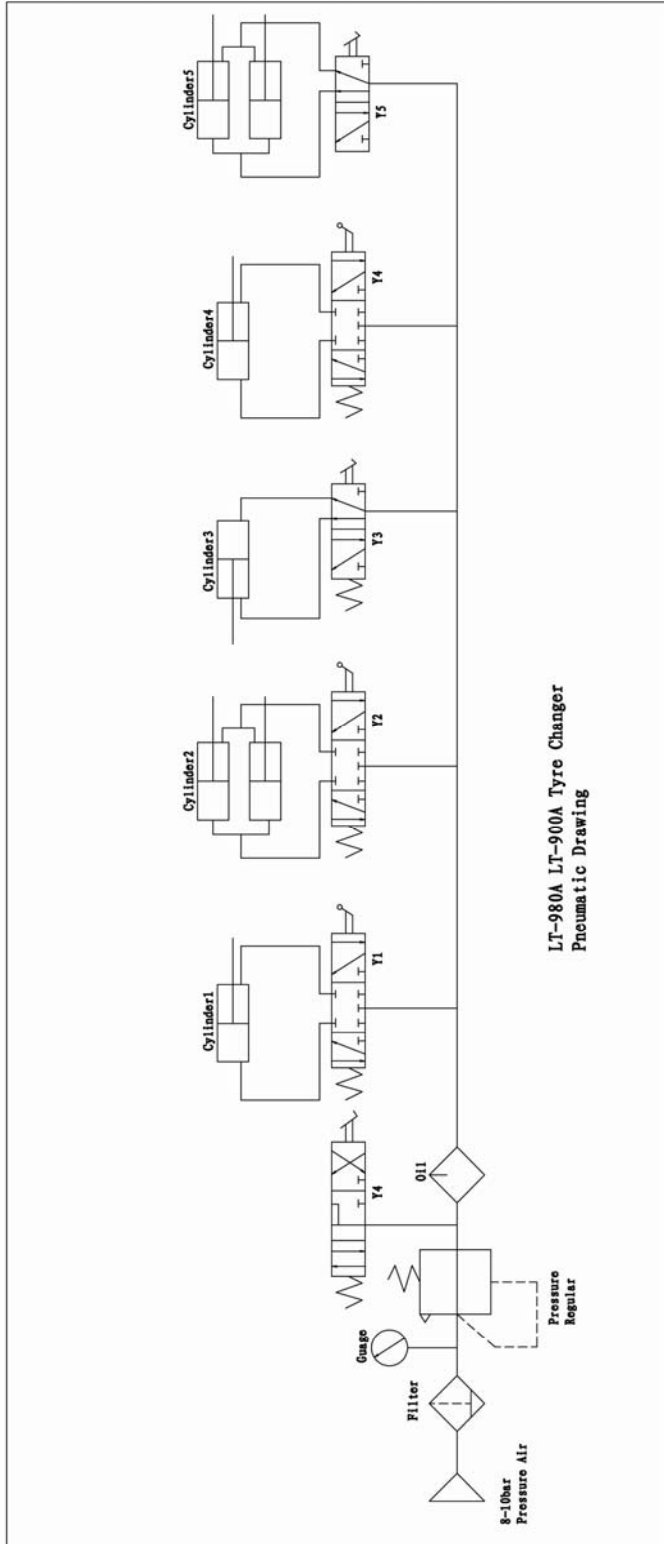

DEKLARACJA ZGODNOŚCI WE
Declaration of Conformity EC



My
We

Nortec Sp. z o.o.
Świerkowa 32
62-020 Rabowice, Poland

Deklarujemy z całą odpowiedzialnością, że produkt

Declare, undertaking sole responsibility, that the product

Montażownica <i>Tyre changer</i>	M0300 / M0320	Numer seryjny <i>Serial number</i>
--	----------------------	--

którego ta deklaracja dotyczy, jest zgodny z następującymi Dyrektywami mającymi zastosowanie:

to which this declaration applies is in compliance with the following applicable Directive(s):

2006/42/WE

DYREKTYWA 2014/30/UE PARLAMENTU EUROPEJSKIEGO I RADY z dnia 17 maja 2006 r. w sprawie maszyn, zmieniająca dyrektywę 95/16/WE (przekształcenie) /Dz. Urz. UE L 157 z 09.06.2006, str. 24-86/

2014/30/UE

DYREKTYWA 2014/30/UE PARLAMENTU EUROPEJSKIEGO I RADY z dnia 26 lutego 2014 r. w sprawie harmonizacji ustawodawstw państw członkowskich odnoszących się do kompatybilności elektromagnetycznej, zastępuje dyrektywę 2004/108/WE

W celu zapewnienia zgodności z wyżej wymienioną dyrektywą zostały zastosowane następujące normy:

in order to ensure compliance with the mentioned Directive(s) have been applied standards listed below:

EN 60204-1:2010

Bezpieczeństwo maszyn - Wyposażenie elektryczne maszyn - Część 1: Wymagania ogólne

EN61000-6-1:2008

Kompatybilność elektromagnetyczna (EMC) - Część 6-1: Normy ogólne - Odporność w środowiskach: mieszkalnym, handlowym i lekko przemysłowym

EN ISO 12100:2012

Bezpieczeństwo maszyn - Ogólne zasady projektowania - Ocena ryzyka i zmniejszanie ryzyka

Podmiotem odpowiedzialnym za dokumentację techniczną jest Nortec Sp. z o.o.

The technical documentation file is constituted by Nortec Sp. z o.o.

Rabowice, 24.10.2022

Beata Broczkowska

Deklaracja została przygotowana zgodnie z normą

The version of this declaration conforms to the regulation

EN ISO/IEC 17050-1